

# 3.0mm .118" Center Wire to Wire/Board Connector



## 5558 Series

### ■ TERMINAL

- Part No.: 5558-TM-T-S
- Material: Phosphor Bronze
- Thickness: 0.2mm
- Plating: Tin plated 60u"
- Wire Range: Suitable for AWG#20~24
- Insulation O.D.: 1.85mm(max)
- Q'TY: 10,000 pcs/reel
- Accepts housing : 5559-HM

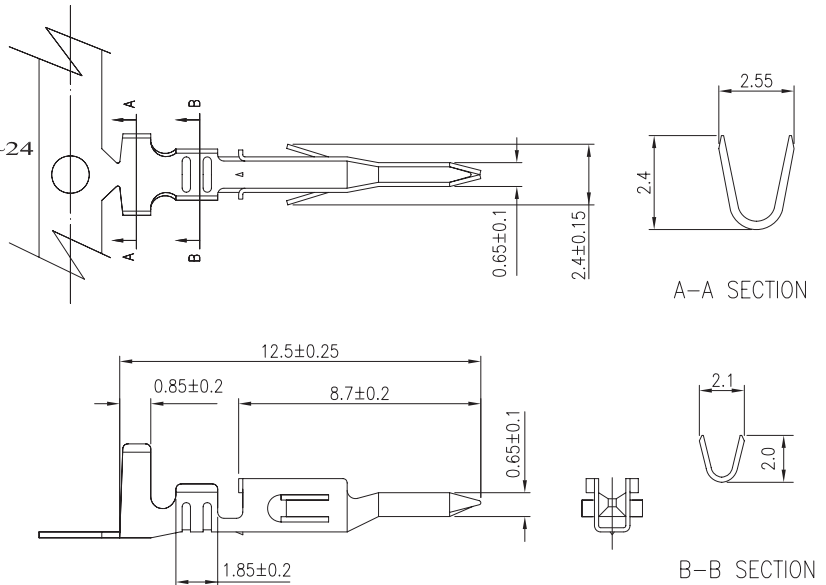

### Ordering Information

Part No.	Wire Range	Insulation O.D.	Material	Finish	Q'ty/reel
5558-TM-T-S	AWG #20~#24	1.85mm(max)	Phos. Bronze	Tin Plated	10,000 pcs

## 5559 Series

### ■ HOUSING

- Part No.: 5559-HM
- Material: Nylon 66, UL94V-0
- Pitch: 3.0mm (.118")
- Poles: 2x1~2x12
- Accepts terminals : 5558-TM-T-S

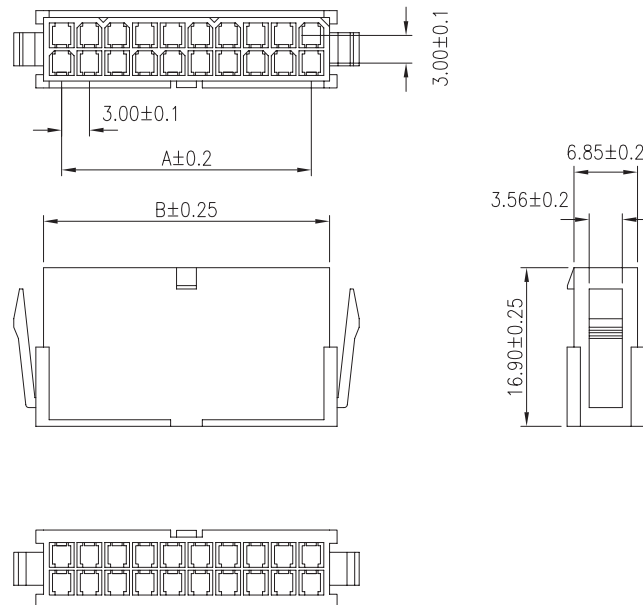
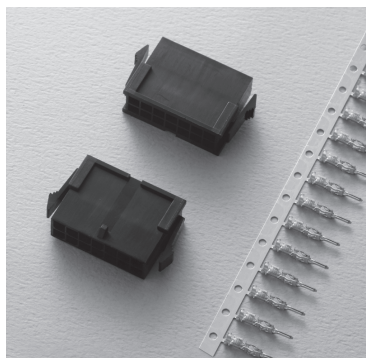

### Ordering Information and Dimensions

CIRCUITS	PART NO.	DIMENSION	
		A	B
2	5559-HM-2X1P	0.00	3.85
4	5559-HM-2X2P	3.00	6.85
6	5559-HM-2X3P	6.00	9.85
8	5559-HM-2X4P	9.00	12.85
10	5559-HM-2X5P	12.00	15.85
12	5559-HM-2X5P	15.00	18.85

CIRCUITS	PART NO.	DIMENSION	
		A	B
14	5559-HM-2X7P	18.00	21.85
16	5559-HM-2X8P	21.00	24.85
18	5559-HM-2X9P	24.00	27.85
20	5559-HM-2X10P	27.00	30.85
22	5559-HM-2X11P	30.00	33.85
24	5559-HM-2X12P	33.00	36.85